

AFFETTATRICI A VOLANO

Swedlinghaus dal 1950®

VOLANO FIORATO



VOLANO PIENO



GLI OPTIONALS

1. PIEDISTALLO

Pedestal
Piétement
Sockel
Pedestal

2. PIEDISTALLO CON RUOTE

Caster-wheeled pedestal
Piétement sur roulettes
Sockel mit Räder
Pedestal con ruedas

3. VOLANO FIORATO

Flower wheel
Volant rosace
Blumenschwungrad
Volante florido

4. FILETTATURA

Border
Bordure
Gewinde
Bordes Fileteados

5. DECORAZIONI

Decorations
Décorations
Dekorationen
Decoraciones

6. PIANO DI MARMO

Marble slice receiving surface
Plateau porte-tranche en marbre
Marmofläche für Wurstwaren
Plato de mármol

7. VERNICIATURA COLORI RAL

RAL colours painting
Vernis couleurs RAL
Lackierung - RAL Farben
Pintura colores RAL

1



2



3

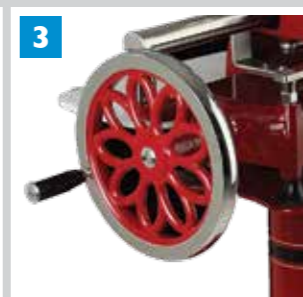

4

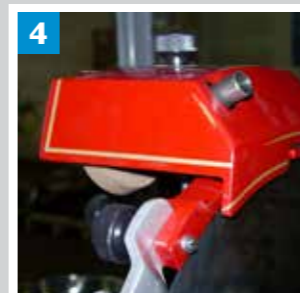

5

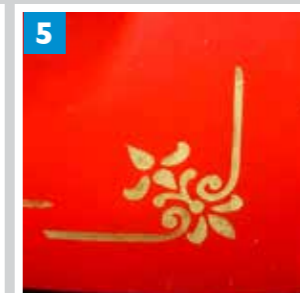

6

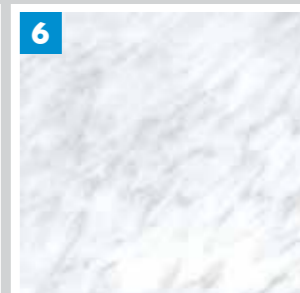

- 🇬🇧 Flywheel manual slicers
- 🇫🇷 Trancheurs manuels à volant
- 🇩🇪 Schwungrad-Aufschnittmaschinen
- 🇪🇸 Cortadoras de fiambres de volante

AF 250VOL
AF 300VOL
AF 350VOL
AF 370VOL



Swedlinghaus®

SWEDLINGHAUS srl • sede centrale
via Enrico Berlinguer, 5
63844 Grottazzolina (FM) • ITALY

Filiale Nord
via Puccini, 11/B
21012 Cassano Magnago (VA) • ITALY

Tel. +39.(0)734.631346
Fax +39.(0)734.632560
e. mail: info@swedlinghaus.it

www.swedlinghaus.it

AFFETTATRICI A VOLANO

mod.AF 250 VOL • mod.AF 300 VOL • mod.AF 350 VOL • mod.AF 370 VOL

Design elegante e raffinato, basate su una produzione di tipo artigianale, queste affettatrici sono particolarmente indicate per il taglio di prosciutti crudi. Struttura in alluminio verniciata a fuoco, parti a contatto con il cibo in acciaio inox. Anello di protezione lama, facilità di smontaggio per la pulizia, funzionamento completamente manuale, affilatoio incorporato.

 **Elegant style, handmade production.** The flywheel slicer is the best choice for slicing Prosciutto. Aluminium construction, stove-enamelled finish, stainless steel food contacting parts. Protection ring around the blade, easy to disassemble for a thorough clean-up, fully hand-operated, built-in sharpener.

 **Style élégant, de fabrication artisanale.** Le trancheur à volant est particulièrement indiqué pour la coupe du jambon. Fabriquée en aluminium, laquée au four, parties au contact des aliments en acier inox. Anneau de protection lame, facilité de démontage pour permettre un nettoyage complet. Entièrement manuelle, affûteur incorporé.

 **Elegantes Design, Handgemachte Herstellung.** Diese Schwungrad-Aufschnittmaschinen sind besonders gut für den Schnitt von Rohschinken geeignet. Struktur aus einbrennlackiertem Aluminium, Teile in Kontakt mit dem Essen aus Edelstahl. Schutzring um dem Messer, einfache Demontage für die Reinigung, voll manuelle Arbeitsweise, eingebauter Messerschärfer.

 **Diseño elegante y refinado, basado en una producción de tipo artesanal,** estas cortadoras de fiambres están particularmente indicadas para el corte de jamones crudos. Estructura en aluminio pintado a fuego, partes en contacto con los alimentos en acero inoxidable. Anillo de protección de la cuchilla, facilidad de remoción para la limpieza, funcionamiento completamente manual, afilador incorporado.

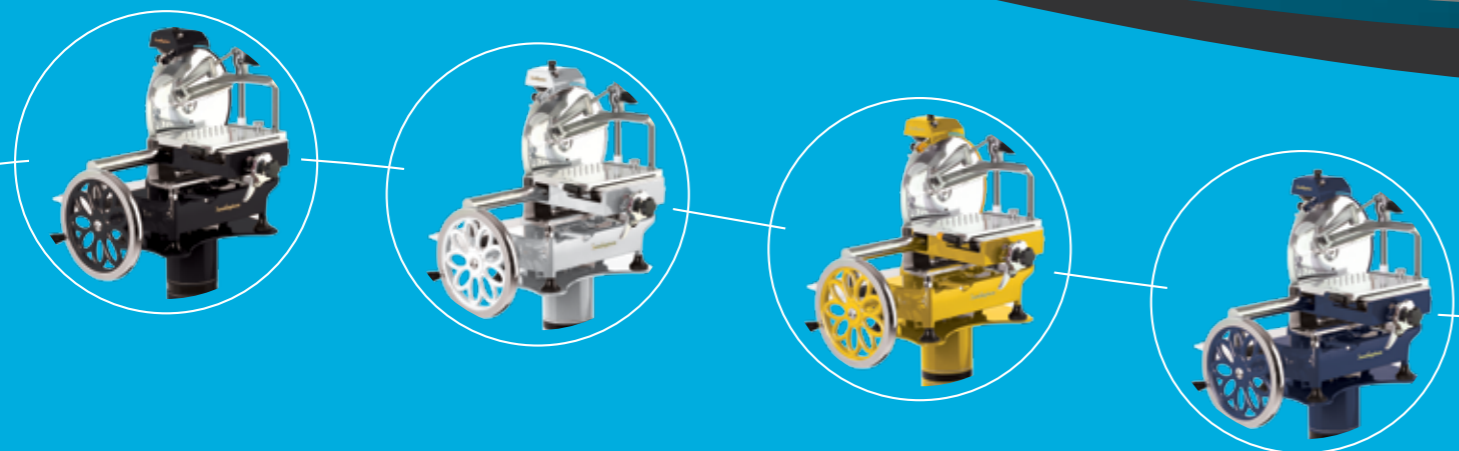

LA SCHEDA TECNICA

- A DISTANZA PIEDINI**
Distance between feet / Distance entre les pieds
Abstand zwischen der Füßchen / Distancia entre los pies
- B INGOMBRO TAGLIO**
Max overall dimension during cutting operation/Dimension max pendant le coupe
Platzbedarf beim Schneiden / Distancia máxima en la fase de corte
- C DISTANZA PIEDINI**
Distance between feet / Distance entre les pieds
Abstand zwischen der Füßchen / Distancia entre los pies
- D INGOMBRO MASSIMO IN LARGHEZZA**
Overall width dimension / Dimension d'encombrement largeur
Maximaler Platzbedarf-Breite / Medida ancho máximo
- E ALTEZZA**
Height / Hauteur / Höhe / Altura
- F INGOMBRO MASSIMO IN ALTEZZA**
Overall height dimension / Dimension d'encombrement hauteur
Maximaler Platzbedarf-Höhe / Medida altura máxima

	AF 250 VOL	AF 300 VOL	AF 350 VOL	AF 370 VOL	PEDESTAL
A	395 mm	435 mm	655 mm	655 mm	
B	690 mm	720 mm	845 mm	845 mm	
C	305 mm	305 mm	400 mm	400 mm	
D	510 mm	560 mm	710 mm	710 mm	
E	500 mm	560 mm	650 mm	650 mm	785 mm
F	500 mm	685 mm	775 mm	775 mm	

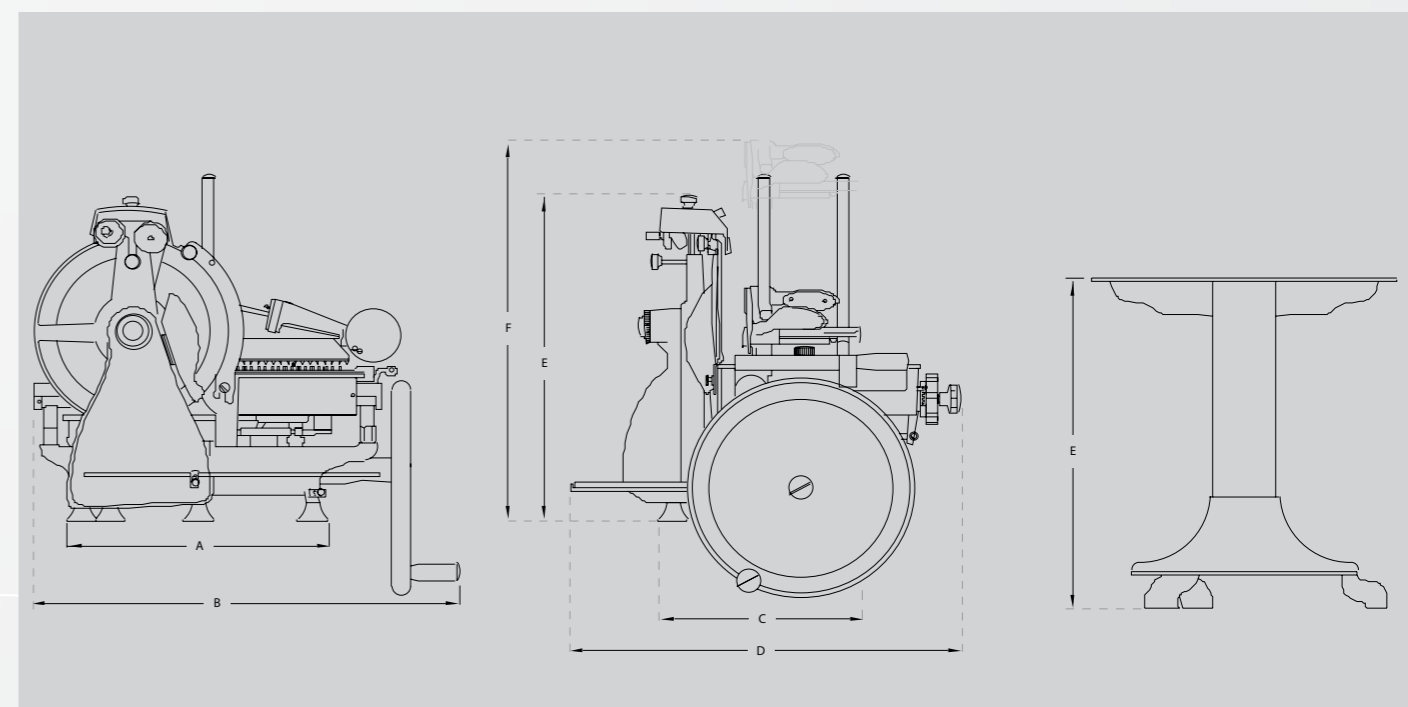

MODELLO	AF 250 VOL	AF 300 VOL	AF 350 VOL	AF 370 VOL	PEDESTAL
CAPACITÀ TAGLIO Cutting capacity / Capacité de coupe Schneidleistung / Capacidad de corte	185x150 mm	220x190 mm	270x250 mm	280x260 mm	
SPESSORE DI TAGLIO Cutting thickness / Épaisseur de coupe Schnittdicke / Espesor del corte	0÷2 mm	0÷2 mm	0÷2,5 mm	0÷2,5 mm	
PESO Weight / Poids / Gewicht / Peso	33 kg	45,5 kg	81 kg	81 kg	65 kg
LAMA DIAMETRO Blade / Lame Messerdurchmesser / Cuchilla	250 mm	300 mm	350 mm	370 mm	
DIMENSIONI PIATTO Carriage dimensions / Dimensions plateau Ausmasse des Schlittentisches/Dimensiones plato	190x145 mm	230x190 mm	275x210 mm	275x210 mm	
DIMENSIONI IMBALLO Packing dimensions/Dimensions emballage Ausmass der Verpackung/Dimensiones embalaje	660x800x690 mm	660x800x690 mm	840x940x970 mm	840x940x970 mm	